

# SHARP®

# AQUOS sense3

## SH-M12

### Quick Start Guide

Refer to the User manual (PDF file) for a detailed explanation of operations.  
It can be downloaded from the following website.

<http://k-tai.sharp.co.jp/support/other/shm12/manual/index.html>



The website can be accessed by scanning the QR code on the left.

## Basic Package

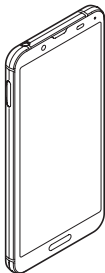

SH-M12 handset  
(With warranty)

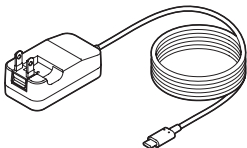

Quick charger  
[AC adapter (SH-AC05)]



Quick Start Guide

- For information on separately sold items compatible with the handset, refer to the following website.  
<http://k-tai.sharp.co.jp/support/other/shm12/index.html>

- Reproduction of this manual in part or in whole without prior permission is prohibited.
- The contents of this manual are subject to change without prior notice.
- Some functions may no longer be available due to changes or termination of OS specifications or services.

## Part Names and Functions

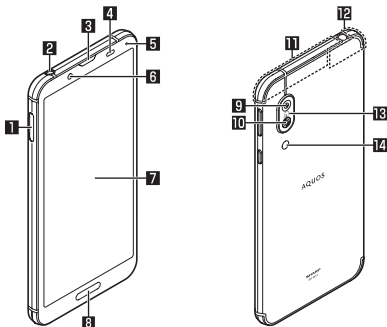

### **1** nanoSIM card and microSD card tray

- It is possible to insert two nanoSIM cards or one nanoSIM card and one microSD card in the nanoSIM card and microSD card tray.

### **2** Earphone/Microphone terminal

### **3** Earpiece/Speaker

### **4** Proximity sensor/Brightness sensor\*1

- Detects the approaching of your face to prevent inadvertent operation during a call and used for automatically controlling the brightness of the screen.

### **5** Incoming/Charging lamp

### **6** Front camera

### **7** Display/Touch panel

### **8** Fingerprint sensor\*1

- Use to unlock the touch panel, etc. by fingerprint authentication.

### **9** Standard camera

- A back camera that can shoot still pictures/videos with a standard lens.

**10 Wide-angle camera**

- A back camera that can shoot still pictures/videos with a wide-angle lens.

**11 Internal antenna\*2**

**12 Bluetooth®/Wi-Fi/GPS antenna\*2**

**13**  **mark**

- IC card is contained (It cannot be removed).

**14 Mobile light/Air vent**

- A mobile light with an air vent to maintain performance.

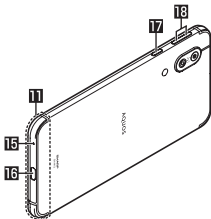

**15 Mouthpiece/Microphone**

- Use as a microphone when recording videos or talking to EMOPA.

**16 USB Type-C™ connection jack**

- Use to charge the handset etc.
- USB Power Delivery is supported.

**17** : **Power key**

- Used to turn the power on/off and turn the screen on/off. Pressing it for at least 2 seconds displays a menu to allow you to operate [Power off], [Restart], [Screenshot], and [Think if it might be a malfunction?].

**18** : **Volume up/down key**

- Use to adjust each volume, shoot with the camera, set manner mode, etc.

\*1 Do not affix a sticker, etc. to the sensor area.



\*2 Built into the main body. Covering the antenna area with your hand may influence the communication quality.

- The back cover cannot be removed. Removing it forcibly may cause damage or a malfunction.
- The battery is built into the handset and you cannot replace it by yourself.

### **Earphone/Microphone**

- Depending on the type of the earphone/microphone, it may not be available.

### **Volume up/down key**

- If you press /  to display the volume bar, the manner mode selection items are displayed ([Manner OFF]/[Vibe]/[Mute]). Touching the key repeatedly allows you to display the item you wish to set and set manner mode.

### **IMEI plate**

- A plate with the sticker which the IMEI information (International Mobile Equipment Identifier), CE mark, etc. are printed is stowed near the nanoSIM card and microSD card tray slot. The IMEI number will be required when you contact the number listed in “General Inquiries” on the warranty. Do not pull out the plate or remove the sticker.

### **To pull out the IMEI plate**

- ① Turn the display side up and then pull out the nanoSIM card and microSD card tray from the handset. For details on how to pull out the nanoSIM card and microSD card tray, refer to  P.6 “Inserting/Removing the Card”.
- ② Turn the display side down, hook the claw part on the back side (side without text printed) of the nanoSIM card and microSD card tray into the hole of the IMEI plate from above and then pull out the IMEI plate. (Remove the nanoSIM card and microSD card from the tray in advance of this.)

\* Do not extract the IMEI plate.

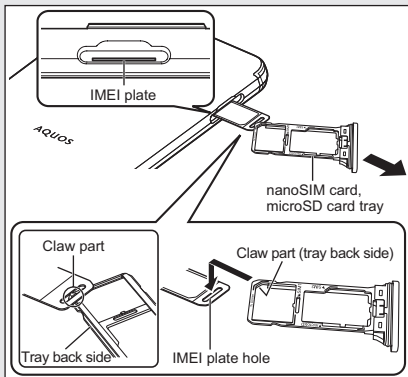

- Note that pulling out the IMEI plate forcibly or adding forces on it may damage to the plate.
- If you accidentally extract the IMEI plate, slowly return the IMEI plate while taking care not to insert it too deep.
- You can also check the IMEI by operating the handset.  
Home screen ► [⊕] ► [System] ► [About phone] ► [IMEI (SIM slot 1)]/  
[IMEI (SIM slot 2)]

## Inserting/Removing the Card

### Inserting a nanoSIM and microSD card

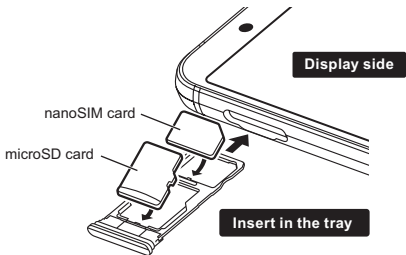

### Inserting two nanoSIM cards

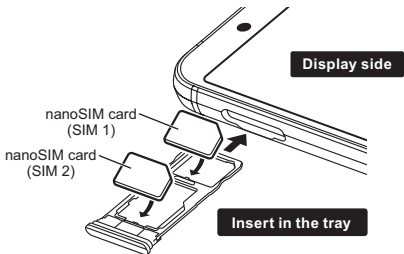

- When inserting/removing a nanoSIM card or microSD card, make sure to insert/remove the card into/from the correct location in the correct direction after you turn off the power.
- The tray is installed in the handset.
- The tray is required to load the nanoSIM card. Make sure not to lose it.
- Hook the tip of your finger into the groove and pull the tray out toward you.
- When inserting the nanoSIM card, load it onto the tray and insert the tray into the handset.
- When inserting the tray, return it to **its original location**. Be sure not to insert it into another place.
- To maintain waterproof/dustproof performance, securely push in the tray and make sure there is no space between the handset and the tray.

## Using the Handset



- The handset supports LTE, W-CDMA, GSM/GPRS and wireless LAN systems.
- Since the handset relies on radio signals, it cannot be used in a place with no signal (such as tunnels, underground, or in buildings), in places with a weak signal, or outside the service area. You may not use the handset in the upper floors of a building even with no obstructions in sight. There may also be times when the signal is strong and  (indicating signal status) is displayed, and you are not moving but the call is interrupted.
- Because the handset uses radio waves, it is possible for a third party to listen in on a conversation. However, since the LTE, W-CDMA and GSM/GPRS systems automatically apply a private call feature to every call, a third party that tries to listen in only hears noise.
- The handset converts conversations into a digital signal and sends it to the other party over the radio. If the signal cannot be reconverted properly by such as moving to an area with a weak signal, the voice may not be heard correctly.
- Take notes of data stored on the handset or save the information to external memory devices such as microSD cards and PCs periodically. Sharp shall not be liable for any loss of content due to a failure, repair, model change or other handling of the handset.
- As with PCs, some user-installed apps, user-accessed websites, etc. may disrupt the stability of your handset performance or unexpectedly transmit information via the Internet causing improper use of your location information, personal information stored on the handset, etc. Therefore, verify the supplier and operating conditions of the apps, websites, etc. to be used before using them.



- The handset automatically performs communication for some functions, for example, to synchronize data, check the latest software version or maintain connection with the server. Also, establishing communication with large-volume data such as downloading apps or watching videos will lead to higher packet communication charges. Subscription to flat-rate packet communication services is highly recommended.
- Even while the Wi-Fi connection is set, packet communication charges may be incurred depending on the app and service you use.
- Some NFC function services related to the contracted carrier's nanoSIM card may no longer be available.
- When the available space on the microSD card or the handset is insufficient, apps in use may not work properly. In this case, delete saved data.
- The handset system can be updated to up-to-date status. Refer to the User manual (in PDF format) for details.
- Secure the security of the handset by setting the password of Screen lock in case you lose it.
- If your handset is lost, change your password for each service account and disable authentication using a PC to prevent other persons from using Google™ services such as Gmail™ and Google Play™, SNS, etc.
- For using services and apps provided by a third party including Google LLC, check the terms of service of Google or the respective providers etc. Sharp shall not be liable for any failure caused by related services and apps.
- If the terms of service etc. is displayed, follow the instructions on the screen and operate.
- Apps and their service contents are subject to change without prior notice.
- The display is manufactured using high-precision technology, but it may contain dots that fail to light or that remain permanently lit on some areas. This is a characteristic of display and not a malfunction.
- Note that Sharp shall not guarantee operation of commercially available peripheral devices.
- This model SH-M12 mobile phone complies with Japanese technical regulations and international guidelines regarding exposure to radio waves. Refer to the User manual (in PDF format) for details on the Specific Absorption Rate (SAR) of the handset.
- Refer to the User manual (in PDF format) for details on the Export Administration Regulations.

## Precautions (ALWAYS FOLLOW THESE DIRECTIONS)

- Before use, read these “Precautions” carefully and use your handset properly. After you have finished reading this guide, keep it in a safe place.
- These precautions contain information intended to prevent bodily injury to the user and to surrounding people, as well as damage to property, and must be observed at all times.
- The following symbols indicate the different degrees of injury or damage that may occur if information provided is not observed and the handset is used improperly.







 <b>Danger</b>	This symbol indicates that death or serious bodily injury <sup>(*1)</sup> may directly and immediately result from improper use.
 <b>Warning</b>	This symbol indicates that “death or serious bodily injury <sup>(*1)</sup> may result from improper use”.
 <b>Caution</b>	This symbol indicates that “minor injury <sup>(*2)</sup> and/or property damage <sup>(*3)</sup> may result from improper use”.

\*1 Serious bodily injury: This refers to loss of eyesight, bodily injury, burns (high- and low-temperature), electric shock, broken bones, injuries with residual aftereffects from poisoning, etc., and injuries requiring hospital admission for treatment or long-term hospital attendance as an outpatient.

\*2 Minor injury: This refers to bodily injury, burns (high- and low-temperature), electric shock, etc. that do not require hospital admission for treatment or long-term hospital attendance as an outpatient.

\*3 Property damage: This refers to extended damage to buildings, furniture, livestock, pets, etc.

■ The following symbols indicate specific directions.

 <p>Prohibited</p> <p>Indicates a prohibited action.</p>	 <p>Do Not Use Wet Hands</p> <p>Indicates not to handle the device with wet hands.</p>
 <p>Do Not Disassemble</p> <p>Indicates not to disassemble the device.</p>	 <p>Instructions</p> <p>Indicates that instructions specified are compulsory (must be followed).</p>
 <p>Keep Dry</p> <p>Indicates not to use the device near water or get it wet.</p>	 <p>Unplug the Power Plug</p> <p>Indicates that the power cord must be unplugged from the outlet.</p>

**Handling the handset, AC adapter and nanoSIM card (general)**

 **Danger**



**Do not use, store or leave the equipment in locations subject to high temperatures or accumulation of heat (near a fire or heating unit, in a kotatsu or bedding, under direct sunlight, inside a vehicle on a hot day, etc.).**

May cause fires, burns, bodily injury, electric shock, etc.



**Do not place the equipment inside cooking appliances such as microwave ovens and induction cookers or high pressure vessels such as pressure cookers, or near them.**

May cause fires, burns, bodily injury, electric shock, etc.



**Do not sprinkle sand, soil or dirt on the equipment or put the equipment directly on it. Also, do not touch the equipment when sand etc. is adhering to your hand.**

May cause fires, burns, bodily injury, electric shock, etc.

Refer to the following for details on waterproofness/dustproofness.

 P.32 "Waterproof/Dustproof/Shockproof Performance"



Prohibited

**Do not charge the equipment while it is wet with liquids such as water (drinking water, sweat, seawater, pet urine, etc.). Also, do not charge the equipment in a location where it will come into contact with water such as a bathroom, etc.**

May cause fires, burns, bodily injury, electric shock, etc.

Refer to the following for details on waterproofness.

☞ P.32 "Waterproof/Dustproof/Shockproof Performance"



Prohibited

**Do not press the equipment strongly or broken it. Especially when carrying the equipment in your pocket, do not allow it to be hit with or nipped in objects.**

May cause fires, burns, bodily injury, etc. because of damage of the internal battery.

\* Take particular care with the followings

- Sitting or squatting down while putting the equipment in your pocket of trousers or skirt
- Allow the equipment to be nipped in the door or vehicular door while putting the equipment in your pocket of outerwear
- Stepping on the equipment while it is placed on a soft object such as the sofa or bedding, floor



Prohibited

**Do not attempt to remove the internal battery from the handset.**

May cause fires, burns, bodily injury, electric shock, etc.



Prohibited

**Do not attempt to remove the back cover from the handset.**

May cause fires, burns, bodily injury, electric shock, etc.



Do Not  
Disassemble

**Do not attempt to disassemble or modify the equipment.**

May cause fires, burns, bodily injury, electric shock, etc.



Keep Dry

**Do not get the equipment wet with liquids such as water (drinking water, sweat, seawater, pet urine, etc.).**

May cause fires, burns, bodily injury, electric shock, etc.

Refer to the following for details on waterproofness.

☞ P.32 "Waterproof/Dustproof/Shockproof Performance"



Keep Dry

**Do not allow liquids such as water (drinking water, sweat, seawater, pet urine, etc.) to get inside the charger terminal or external connection jack.**

May cause fires, burns, bodily injury, electric shock, etc.

Refer to the following for details on waterproofness.

☞ P.32 "Waterproof/Dustproof/Shockproof Performance"



Instructions

**Always use the specified AC adapter with this handset.**

May cause fires, burns, bodily injury, electric shock, etc. if you use a device other than specified one.

## Warning



Prohibited

**Do not subject the equipment to strong force, impacts or vibration such as letting it fall, stepping on it or throwing it.**

May cause fires, burns, bodily injury, electric shock, etc.



Prohibited

**Do not allow conductive materials (such as metal objects and pencil lead) to come into contact with the charger terminal or external connection jack or dust to get inside it.**

May cause fires, burns, bodily injury, electric shock, etc.



Prohibited

**Do not cover or wrap the equipment with bedding etc. when using or charging.**

May cause fires, burns, etc.



Instructions

**If charging is not completed after the specified charging time, stop charging.**

May cause fires, burns, bodily injury, etc. because of overcharging.



Instructions

**Be sure to turn off the handset and not to charge the battery in locations where flammable gas may be generated and where dust is generated.**

The flammable gas, etc. could ignite, causing a fire, explosion, etc.



Instructions

**Follow the instructions given by the respective facility regarding use of the handset in a gas station.**

Do not perform charging in a gas station, etc.

Also, take care not to drop the handset when using it in a gas station, etc. In particular, do not use the handset when refilling a vehicle with gas.

The flammable gas, etc. could ignite, causing a fire, explosion, etc.



Instructions

**If any trouble such as an unusual odor, unusual noise, smoking, overheating, discoloration or deformation is found during use, charge or storage, follow the instructions below.**

- Unplug the power plug from the outlet.

- Turn off the handset.

May cause fires, burns, bodily injury, electric shock, etc. if you do not follow the instructions above.

## **Caution**



Prohibited

**Do not use a damaged equipment.**

May cause fires, burns, bodily injury, etc.



Prohibited

**Do not leave the equipment on unstable surfaces, such as on a wobbly table or sloped surface. Be very careful while the vibrator is set.**

May fall and cause injury etc.



Prohibited

**Do not use or store the equipment in locations that are subject to humidity, dust or high temperatures.**

May cause fires, burns, electric shock, etc.

Refer to the following for details on waterproofness/dustproofness.

 P.32 "Waterproof/Dustproof/Shockproof Performance"



Prohibited

**If being used by a child, have a guardian teach him/her the proper handling procedures and do not have him/her use it improperly.**

May cause bodily injury etc.



Prohibited

**Do not place the equipment where the young children can reach it.**

**Be especially careful with regard to the storage location of small parts such as the nanoSIM card and microSD card tray.**

A young child may swallow the equipment, or suffer bodily injury, electric shock, etc.



Instructions

**Be careful when using the handset continuously or when charging because it may become warm. Also, be careful not to unintentionally touch it continuously when it is in a pocket of your clothing, or when you fall asleep, etc.**

The handset or AC adapter may become warm when using an app, a call, data communication, watching video, etc. for a long time or charging. Directly touching a warmed part for a long time may cause redness, itching, rashes, low-temperature burns, etc. on your skin depending on your constitution or health condition.

## Handling the handset

### **Danger**



Prohibited

**Do not throw the handset into a fire or heat it.**

May cause fires, burns, bodily injury, etc.



Prohibited

**Do not apply excessive force on the handset such as puncturing it with a sharp object (nail, etc.), hitting it with a hard object (hammer, etc.) or stepping on it.**

May cause fires, burns, bodily injury, etc.



Instructions

**If the substance inside the handset comes into contact with your eyes or mouth, etc. immediately rinse the contacted area with clean water. Then seek prompt medical treatment.**

May result in loss of eyesight, sick, etc. because of the substance etc. inside the handset.

# Warning



Prohibited

**Do not point the illuminated light directly at someone's eyes. Especially when you use it for young children, keep sufficient distance from them.**

Do not use mobile light near people's faces. Eyesight may be temporarily affected leading to accidents etc.



Prohibited

**Do not illuminate or emit the mobile light at anyone driving a car or other vehicles.**

May prevent a driver from driving safely and cause a traffic accident etc.



Prohibited

**Do not watch the screen which is flashing repeatedly for a long time.**

May cause spasm or loss of consciousness.



Prohibited

**Do not allow water or other liquids (drinking water, sweat, seawater, pet urine, etc.), metal (a blade of cutter, staple, etc.), flammable material or other foreign object to enter the nanoSIM card and microSD card tray slot on the handset. Also, do not insert a nanoSIM card or microSD card in the wrong place or facing the wrong way.**

May cause fires, burns, bodily injury, electric shock, etc.



Prohibited

**Do not expose the camera lens to direct sunlight etc. for an extended period.**

May cause fires, burns, bodily injury etc. because of the light-collecting mechanism of the lens.



Instructions

**Turn off the handset or set it to In Airplane mode before going aboard an airplane.**

Since using the handset on airplanes is restricted, follow the instructions given by the respective airlines.

May interfere with the operation of electronic devices installed on the airplane because of signals.

If you commit a prohibited act while using the handset on an airplane, you may be punished by law.





Instructions

---

**Follow the instructions given by the respective medical facility regarding the use of the handset in a hospital.**

Turn off the handset in areas where the use of mobile phones is prohibited.

May interfere with the operation of electronic devices and electronic medical equipment because of signals.

---



Instructions

**Keep the handset away from the ears during a call in which hands-free is set, while the ringtone is ringing loudly, during stand-by, etc.**

**When you attach the earphone/microphone etc. to the handset to play games, video/music, etc., do not make the volume too loud.**

During a call in which hands-free is set, loud sounds are being emitted from the handset.

Even during stand-by, the ringtone or alarm sound may activate suddenly. Hearing loud sounds for a long time may damage your hearing such as difficulty in hearing.

Also, excessively high volume prevent you from hearing ambient sounds and cause an accident.

---



Instructions

**If you have a weak heart, take extra precautions when setting functions such as the vibrator and ringtone volume for incoming calls.**

You may be startled at the sudden vibrator and ringing for incoming calls, and may have harmful effects on your heart.

---



Instructions

**If you are using electronic medical equipment etc., contact the respective manufacturer or dealer to check whether the operation of the equipment is affected by signals.**

May interfere with the operation of electronic medical equipment etc. because of signals.

---



Instructions

**Turn off the handset near high-precision electronic devices or devices that use weak electronic signals.**

May interfere with the operation of electronic devices because of signals.

\* Take particular care with the following devices

Hearing aids, implanted cardiac pacemakers, implanted cardioverter-defibrillators, other electronic medical equipment, other equipment controlled by electronic signals, etc. If you use an implanted cardiac pacemaker, implanted cardioverter-defibrillator or other electronic medical equipment, contact the respective manufacturer or dealer to check whether the operation of the equipment is affected by signals.



Instructions

**If the display part or camera lens is damaged, be careful of broken glass and the exposed inside of the handset.**

May cause burns, bodily injury, electric shock, etc. if you touch the broken or exposed parts.



Instructions

**If the substance inside the internal battery leaks, or the internal battery emits an unusual odor, immediately stop using the handset and move it away from any naked flames or fire.**

The battery fluid is flammable and could ignite, causing a fire, explosion, etc.



Instructions

**Do not allow a pet etc. to bite the handset.**

May cause fires, burns, bodily injury, etc. because of damage of the internal battery.

## **Caution**



Prohibited

**For using a motion sensor and geomagnetic sensor, check the safety around, hold the handset and do not swing it more than necessary.**

May cause an accident such as bodily injury.



Prohibited

**If the display is broken and the internal substance then leaks, do not get it on your skin (face, hands, etc.), clothes, etc.**

May result in damage to your eyes, skin, etc.

If the internal substance comes into contact with your eyes, mouth, skin or clothes, etc. immediately rinse the contacted area with clean water. Also, if it comes into contact with your eyes or mouth, etc. seek medical treatment immediately after rinsing the contacted area.



Prohibited

**Do not dispose of the handset in ordinary garbage.**

May cause fires, burns, bodily injury, etc. It may also cause damage to the environment. For information on what to do with unnecessary handsets, contact the number listed in "General Inquiries" on the warranty or follow the instructions by a local institution that handles used handsets.



Prohibited

---

**If the substance inside the internal battery leaks, do not get the liquid on your skin (face, hands, etc.), clothes, etc.**

May result in damage to your eyes, skin, etc.

If the internal substance comes into contact with your eyes, mouth, skin or clothes, etc. immediately rinse the contacted area with clean water. Also, if it comes into contact with your eyes or mouth, etc. seek medical treatment immediately after rinsing the contacted area.

---



Instructions

**If you use the handset in a vehicle, contact the vehicle manufacturer or dealer to check whether the operation of the vehicle is affected by signals.**

May interfere with the operation of electronic equipment because of signals in some vehicle models. In this case, stop using the handset.

---



Instructions

**If any trouble on your skin occurs due to using the handset, immediately stop using it and seek medical treatment.**

Use of the handset may cause itching, rashes, eczema, etc. depending on your constitution or health condition.

Refer to the following for details on materials of each part.

 P.23 "Material list"

---



Instructions

**Make sure that there is no metal (a blade of cutter, staple, etc.) on the handset because the earpiece/speaker section contain parts that generate magnetic waves.**

May cause bodily injury etc. because of the adhered object.

---



Instructions

**Look at the display in a well-lit place, keeping a certain distance.**

Eyesight may be weakened etc. if you look at it in a dark place or closely.

# Warning



Prohibited

**Do not use if the cable of the AC adapter is damaged.**

May cause fires, burns, electric shock, etc.



Prohibited

**Do not touch AC adapter if you hear thunder.**

May cause electric shock etc.



Prohibited

**Do not short-circuit the charger terminal when connected to an outlet. Also, do not allow any part of your body (hands, fingers, etc.) to come into contact with the charger terminal.**

May cause fires, burns, electric shock, etc.



Prohibited

**Do not place heavy objects on the cable of the AC adapter or apply excessive force on it such as pulling it.**

May cause fires, burns, electric shock, etc.



Prohibited

**When plugging/unplugging an AC adapter into/from the outlet, do not allow metallic objects to come into contact with the prongs of the plug.**

May cause fires, burns, electric shock, etc.



Prohibited

**Do not connect the voltage converter for overseas travel (travel converter) to the AC adapter.**

May catch fire, or cause overheat, electric shock, etc.



Prohibited

**Do not apply excessive force on the connection part with the AC adapter connected to the handset.**

May cause fires, burns, bodily injury, electric shock, etc.



Do Not Use  
Wet Hands

**Do not handle the AC adapter cable, charger terminal, or power plug with wet hands.**

May cause fires, burns, electric shock, etc.



Instructions

**Always use the specified power supply and voltage. When recharging the handset overseas, use an AC adapter that can be used overseas.**

Using the incorrect power supply and voltage may cause fires, burns, electric shock, etc.

Specified AC adapter: 100V AC to 240V AC (exclusively for household AC outlets)



Instructions

**Wipe off any dust on the power plug.**

May cause fires, burns, electric shock, etc. if you use the power plug with dust adhering.



Instructions

**Fully plug the AC adapter into the outlet.**

May cause fires, burns, electric shock, etc. if you do not insert it securely.



Instructions

**When unplugging the power plug from the outlet, grasp the AC adapter and do not apply excessive force on it such as pulling the AC adapter cable.**

May cause fires, burns, electric shock, etc. since the cable of the AC adapter is damaged by pulling it.



Instructions

**When plugging/unplugging an AC adapter into/from the handset, plug/unplug it straightly toward the terminal to connect, not applying excessive force on it such as pulling the cable.**

May cause fires, burns, bodily injury, electric shock, etc. if you do not plug/unplug it correctly.



Instructions

**If the charger terminal is deformed such as bending it, immediately stop using. Also, do not use the deformed one by returning it to the original shape.**

May cause fires, burns, bodily injury, electric shock, etc. because of short circuit of it.



Unplug the  
Power Plug

**If you are not going to use the AC adapter, grasp the AC adapter and unplug the power plug from the outlet.**

May cause fires, burns, electric shock, etc. if you leave the power plug with it plugged into the outlet or accessory socket.



Unplug the  
Power Plug

**If a liquid such as water (drinking water, sweat, seawater, pet urine, etc.) adheres to the device, immediately grasp the AC adapter and remove the power plug from the outlet.**

May cause fires, burns, electric shock, etc. because of short circuit by the adhered object.



Unplug the  
Power Plug

**Grasp the AC adapter and unplug the power plug from the outlet before cleaning the device.**

May cause fires, burns, electric shock, etc. if you do not unplug it.

## **Caution**



Prohibited

**Do not touch the AC adapter continuously while it is connected to an outlet.**

May cause burns etc.

## Handling the nanoSIM card

## **Caution**



Instructions

**Be careful not to injure any part of your body, such as fingers, with the notch section when handling the nanoSIM card.**

May cause bodily injury etc. because the cutting surface may be sharp.

# Warning



Instructions

**If you have electronic medical equipment such as an implanted cardiac pacemaker or an implanted cardioverter-defibrillator, always carry or use your handset at least 15 cm away from your implant.**

Electromagnetic signals may have harmful effects on the operation of the electronic medical equipment.

---



Instructions

**Patients receiving medical treatment away from a medical facility (e.g. home treatment) who are using electronic medical equipment other than implanted cardiac pacemakers or implanted cardioverter-defibrillators should consult the respective manufacturers, etc. for information regarding the effects of signals on the equipment.**

Electromagnetic signals may have harmful effects on the operation of the electronic medical equipment.

---



Instructions

**If there is any chance that the distance between the handset and a person closest to you may get shorter than 15 cm such as when you cannot freely move around, set the handset not to emit radio wave in advance (by setting In Airplane mode, turning the power off, etc.).**

Somebody nearby may be equipped with electronic medical equipment such as an implanted cardiac pacemaker or an implanted cardioverter-defibrillator. Electromagnetic signals may have harmful effects on the operation of the electronic medical equipment.

---



Instructions

**Follow the instructions given by the respective medical facilities regarding the use of the handset on their premises.**

Electromagnetic signals may have harmful effects on the operation of the electronic medical equipment.

## Material list

### Handset

Part	Material/Surface treatment
Display side	Reinforced glass/AF coating
Exterior	Aluminum/Anodizing
Exterior (Antenna section)	PBT resin (With glass)
Power key	Aluminum/Anodizing
Volume up/down key	Aluminum/Anodizing
Fingerprint sensor	Epoxy resin/Hard coating
Decoration of fingerprint sensor	Stainless/PVD processing
Camera panel	Reinforced glass/AF coating, AR coating
Decoration of camera	Aluminum/Anodizing
Mobile light	PC resin
Earpiece/Speaker mesh	PC resin
Surrounding area of earphone/ microphone terminal (inner side surface)	PBT resin (With glass)
Surrounding area of USB Type-C connection jack (inner side surface)	PBT resin (With glass)
nanoSIM card and microSD card tray (exterior section)	Aluminum/Anodizing
nanoSIM card and microSD card tray	POM resin
Gasket of the nanoSIM card and microSD card tray	Silicon rubber
IMEI plate	PET resin/Laminate

### AC adapter (SH-AC05)

Part	Material/Surface treatment
AC adapter unit (Housing section)	PC resin + MBS (Polycarbonate alloy)
AC adapter unit (Plug resin section)	PBT resin
AC adapter unit (Plug metal section)	Brass/Nickel plating
AC adapter unit (Plug tracking resistance section)	PA (Polyamide)
Cable	PVC
USB Type-C plug (Housing section)	PVC
USB Type-C plug (Metal section)	Stainless steel/Nickel plating



## Handling Precautions

### General notes

---

- **The SH-M12 is waterproof/dustproof, however, do not allow liquid such as water (drinking water, sweat, seawater, pet urine, etc.) or foreign objects such as dust get inside the handset and do not allow them to adhere to the specified AC adapter.**

The specified AC adapter and nanoSIM card are not waterproof/dustproof. Do not use in humid or steamy areas such as bathrooms and places exposing to rain and other forms of moisture. If they are carried close to the skin, perspiration may cause internal components to corrode and result in malfunction. If a problem is found to be due to moisture, the handset and parts are not covered by warranty. For details on repair, contact the number listed in "General Inquiries" on the warranty.

- **Clean only with a soft and dry cloth (such as the type used for eyeglasses).**
  - Forceful rubbing of the display may scratch its surface.
  - Water drops, dirt, etc. left on the display may cause stains to form on its surface.
  - Never use chemicals such as alcohol, thinners, benzene or detergents, as these agents may erase the printing or cause discoloration.

- **Occasionally clean terminals, the fingerprint, etc. and always keep it.**

When using unclean terminals etc., the handset may not work properly. Be careful not to damage to terminals etc. while cleaning them.

- **Do not place the equipment near an air conditioning vent.**

Condensation formed due to rapid changes in temperature may cause internal corrosion and lead to a malfunction.

- **Do not apply excessive force on the handset when using it.**

Carrying the equipment in a tightly packed bag or sitting on it put in your pocket may cause a malfunction or damage of the display, internal components, internal battery, etc.

Keeping an external connector device plugged into the external connection jack may cause a malfunction or damage.

- **Do not drop or otherwise subject the equipment to severe impact.**

May cause a malfunction or damage.

- **Note that malfunctions deemed to be caused by inappropriate operation by the customer are not covered by the warranty.**

## Notes about the handset

---

- **Do not forcefully press the display or operate with a pointed object.**  
May scratch it and cause malfunction or damage.
- **Avoid using the handset in extremely high or low temperatures.**  
Use the handset within the range of a temperature between 5°C and 35°C and a humidity between 45% and 85%.  
Refer to the User manual (in PDF format) for details on use in a bathroom.
- **Using the handset close to household electronic equipment (TVs, radios, etc.) may have harmful effects on the operation of such equipment. Move as far away as possible from such items before use.**
- **Back up to the microSD card, PC, cloud, etc. or keep a separate memo of data stored on the handset.**  
Sharp shall not be liable for any loss of content.
- **When connecting an external connector device to the external connection jack, do not put it in obliquely and do not pull it while it is plugged in.**  
May cause a malfunction or damage.
- **The handset may become warm during use or charging but this is not a malfunction. You can keep using it.**
- **Do not leave the camera lens in direct sunlight.**  
May cause discoloration or burn-in of pixels.
- **Normally, use the handset with the nanoSIM card and microSD card tray closed.**  
Liquid such as water (drinking water, sweat, seawater, pet urine, etc.) or foreign object such as dust may get inside and cause a malfunction.
- **Do not give a strong impact on the fingerprint sensor or scratch the surface.**  
May cause not only malfunction of the fingerprint sensor but also disabling authentication.
- **While using a microSD card, do not remove the card or turn off the handset.**  
May cause data loss or a malfunction.
- **Never place a magnetic card or magnetized items near the handset.**  
The data stored in cash cards, credit cards, transport system IC cards, etc. may be erased.  
Putting highly magnetized items closer may cause an error.
- **Do not decorate the handset with films, stickers, etc.**  
Each function for using the proximity sensor may not work normally.  
Refer to the following for details on the position of the proximity sensor.  
 P.2 "Part Names and Functions"

● **The internal battery is a consumable product.**

Depending on usage, the internal battery may swell as it approaches the end of its usable life.

Change the battery if its life becomes extremely shorter or the it swells even after fully charged. Refer to the following for details on replacing the internal battery.

☞ P.37 "Replacing the Internal Battery"

● **Charge the battery in areas where the ambient temperature is between 5°C and 35°C.**

● **The battery life depends on the usage and deterioration of the battery.**

● **Do not store the handset under the following situations because they may lower the performance or shorten the usable life of the internal battery.**

- Storage with the internal battery fully charged (immediately after charging is completed)
- Storage with no battery level (cannot turn the handset on)

Approximately 40% is recommended as the proper battery level for storage.

● **The following is the type of the internal battery built into the handset.**

Label	Battery type
Li-ion00	Lithium-ion

● **The surface of the handset uses the aluminum material. Note that dent and abrasion are easily remained as aluminum is a soft material.**

### Notes about AC adapter

---

● **Use the specified AC adapter for charging.**

● **Charge the battery in areas where the ambient temperature is between 5°C and 35°C.**

● **Do not charge the internal battery in the following locations.**

- Areas with high humidity or dust, or in areas exposed to frequent vibrations
- Close to household electronic equipment (TVs, radios, etc.)

● **AC adapters may become warm during charging but this is not a malfunction. You can keep using it.**

● **When using an outlet with a feature to prevent the plug from being removed accidentally, follow the instructions in the outlet user's guide.**

● **Do not subject to strong impacts. Also, do not deform the charger terminals.**

May cause a malfunction.

## Notes on the nanoSIM card

---

- **Do not apply unnecessary force when inserting/removing the nanoSIM card.**
- **Please note that you are responsible for malfunctions arising from inserting the nanoSIM card into another device such as an IC card reader/writer.**
- **Occasionally clean IC area and always keep it.**  
When using the card while IC area is not clean, it may not work properly.
- **Clean only with a soft and dry cloth (such as the type used for eyeglasses).**
- **Data stored on the nanoSIM card should be backed up to a microSD card, PC, cloud, etc. or kept in a separate memo.**  
Sharp shall not be liable for any loss of content.
- **Do not damage, touch haphazardly or short-circuit the IC.**  
May cause data loss or a malfunction.
- **Do not drop or otherwise subject the nanoSIM card to a severe impact.**  
May cause a malfunction.
- **Never bend the nanoSIM card or place heavy objects on it.**  
May cause a malfunction.
- **Do not insert the nanoSIM card to the handset with a label, sticker, etc. attached on the card.**  
May cause a malfunction.

## Notes on using Bluetooth function

- The handset supports the security function that meets the Bluetooth specification for security during communication using Bluetooth functions. However, the security may not be sufficient depending on the configuration etc. Take care of the security while making communication using Bluetooth function.
- Even if any leak of data or information occurs while making communication using Bluetooth function, Sharp shall not be liable for any loss of content.
- **Radio frequencies**

Select home screen ► [⊙] ► [System] ► [Advanced] ► [Authentication] to confirm the radio frequencies that the Bluetooth function of the handset uses. The label markings are as follows.



- ① 2.4: This radio equipment uses the 2,400 MHz band.
  - ② FH: The modulation system is the FH-SS system.
  - ③ 4: The estimated coverage distance is 40m or less.
  - ④ XX: Another modulation system is used.
  - ⑤ 8: The estimated coverage distance is 80m or less.
  - ⑥ [Black bar with two white vertical bars]: All radio frequencies between 2,400 MHz and 2,483.5 MHz are used and the frequencies for mobile object identifiers cannot be avoided.
- **Cautions on using Bluetooth devices**
- Bluetooth operates at radio frequencies assigned to the in-house radio stations for a mobile object identifier that have to be licensed and are used in production lines of a factory, specific unlicensed low power radio stations, and amateur radio stations (hereafter, referred to as "another radio station") in addition to industrial, scientific and medical devices or home electric appliances such as microwave ovens.
1. Before using the handset, make sure that "another radio station" is not operating nearby.
  2. If radio interference between the handset and "another radio station" occurs, avoid interference by moving immediately to another place or "turning off the power".
  3. For further details, contact the number listed in "General Inquiries" on the warranty.

## Notes about wireless LAN (WLAN)

- **Wireless LAN (WLAN) uses radio waves to communicate information.** Therefore, it has an advantage of freely connecting to the LAN within the service area. On the other hand, if security setting is not set, it is possible for a malicious third party to intercept the communication contents or hack. It is recommended to set security setting at your own risk and judgement.
- **Even if any leak of data and information occurs while making communication using wireless LAN function, Sharp shall not be liable for any loss of content.**

### ● **Wireless LAN**

Do not use wireless LAN near magnetic devices such as electric appliances or AV/OA devices or in radio waves.

- Magnetism or radio waves may increase noises or disable communications (especially when using a microwave oven).
- When used near TV, radio, etc., reception interference may occur or channels on the TV screen may be disturbed.
- If there are multiple wireless LAN access points nearby and the same channel is used, search may not work correctly.

### ● **Radio frequencies**

Select home screen ► [(⊕)] ► [System] ► [Advanced] ► [Authentication] to confirm the radio frequencies that the wireless LAN function of the handset uses. The label markings are as follows.



- ① 2.4: This radio equipment uses the 2,400 MHz band.
- ② DS: The modulation system is the DS-SS system.
- ③ OF: The modulation system is the OFDM system.
- ④ 4: The estimated coverage distance is 40 m or less.
- ⑤ [ ] [ ] [ ]: All radio frequencies between 2,400 MHz and 2,483.5 MHz are used and the frequencies for mobile object identifiers can be avoided.

Available channels for the handset's wireless LAN are between 1 and 13. Note that other channel access points cannot be connected.

Available channels may vary depending on the country.

For use in an aircraft, contact the airline beforehand.

### ● Cautions on using 2.4 GHz devices

WLAN-installed devices operate at radio frequencies assigned to the in-house radio stations for a mobile object identifier (radio stations requiring a license) used in production lines of a factory, specific low power radio stations (radio stations requiring no license), and amateur radio stations (radio stations requiring a license) in addition to industrial, scientific and medical devices or home electric appliances such as microwave ovens.

1. Before using this device, make sure that the in-house radio stations for a mobile object identifier, specific low power radio stations and amateur radio stations are not operating nearby.
2. If the device causes harmful radio interference to the in-house radio stations for a mobile object identifier, immediately change the radio frequency or stop use, and contact the number in "General Inquiries" on the warranty for crosstalk avoidance, etc. (e.g. partition setup).
3. If the device causes radio interference to specific low power radio stations for a mobile object identifier or amateur radio stations, contact the number in "General Inquiries" on the warranty for further details.

### ● Cautions on using 5GHz devices

In the 5 GHz frequency band, three bands of 5.2 GHz/5.3 GHz/5.6 GHz band (W52/W53/W56) are available.

- W52 (5.2 GHz band/36, 40, 44, 48 ch)
- W53 (5.3 GHz band/52, 56, 60, 64 ch)
- W56 (5.6 GHz band/100, 104, 108, 112, 116, 120, 124, 128, 132, 136, 140 ch)

Using 5.2 GHz/5.3 GHz band wireless LAN (W52/W53) outdoors is prohibited by the law (except when communicating with an access point/relay station of a 5.2 GHz band high power data communication system).

## Voluntary control for radio wave interference

### ● This product satisfies technical requirements based on VCCI Rules for Voluntary Control Measures and its satisfied mark is displayed on the electronic nameplate of the product.

You can see the electronic nameplate by operating the product as follows.

Home screen ► [🌀] ► [System] ► [Advanced] ► [Authentication]



## FeliCa and NFC reader/writer

---

- The FeliCa, NFC reader/writer and P2P function of the handset use weak radio waves whose handling does not require a license of radio station.
- The frequency in use is the 13.56 MHz band. When another FeliCa, NFC reader/writer or P2P function is being used nearby, keep enough distance from it.  
Make sure that there is no radio station using the same frequency band in the area nearby.
- For use in an aircraft, contact the airline beforehand. Use of the function may be restricted in some countries.  
Check conditions such as regulations of the country/region to use the function.

## Caution

---

- **Never use the handset that is modified. Using a modified device violates the Radio Law and/or the Telecommunications Business Law.**  
The handset follows the regulations regarding the certification of conformity with technical regulations for specific radio stations etc. based on the Radio Law and authentication of conformity with technical regulations for devices etc. based on the Telecommunications Business Law, and the "Technical Conformity Mark " can be displayed on the electronic nameplate of the handset as a proof. You can see it by operating as follows.  
Home screen ► [] ► [System] ► [Advanced] ► [Authentication]  
If a modification is given to the inside, the certification of conformity with technical regulations, etc. will become invalid. Never use the handset without the valid certification etc. Doing so violates the Radio Law and/or the Telecommunications Business Law.
- **Be careful when using the handset while driving a motor vehicle.**  
Using the handset in hand while driving is regarded as a punishable act. However, the punishment has no application in some cases such as when rescuing sick and injured people or maintaining public safety.
- **The FeliCa and NFC reader/writer function of the handset conform to the domestic radio wave standards.**  
When you use it overseas, check conditions such as regulations of the country/region in advance.
- **Never change the basic software improperly.**  
This may be regarded as a conversion of software and repairs may be refused.



## Waterproof/Dustproof/Shockproof Performance

The SH-M12 is waterproof to IPX5\*1 and IPX8\*2 standards, and dustproof to IP6X\*3 standard if the nanoSIM card and microSD card tray is securely closed. The handset adapts a shockproof construction that passed Military Standard compliant tests\*4.

- \*1 IPX5 means that the communication device keeps functioning after being subjected to a jet flow (12.5 L/min) discharged from a nozzle (inner diameter: 6.3 mm), from all directions (approximately 3 m from the handset) for 3 minutes or more.
- \*2 IPX8 means that the communication device keeps functioning after the mobile phone is slowly submerged to depth of 1.5 m in static tap water at room temperature, left there for approximately 30 minutes and then taken out.
- \*3 IP6X means the level of dust protection. Mobile phone has the ability to prevent dust from entering inside after it is left in the device containing dust (diameter: 75 μm or smaller) for 8 hours, agitated and then taken out.
- \*4 Military Standard compliant  
Original testing conforming to U.S. Department of Defense MIL-STD-810H standard has been conducted on this handset.

### What you can do with waterproof/dustproof of SH-M12

---

- Refer to the User manual (in PDF format) for details on what you can do with the waterproof/dustproof performance of the SH-M12.

### Things to keep in mind

---

To maintain waterproof/dustproof performance, check the followings.

- Close the nanoSIM card and microSD card tray properly. Be careful not to apply excessive force on the rubber gasket when opening and closing.
- Make sure that the nanoSIM card and microSD card tray is completely closed without floating.
- In order to maintain the waterproof/dustproof performance, the nanoSIM card and microSD card tray is designed so it can be securely closed. Note that opening it forcibly may cause injuries to your nails, fingers, etc.
- Refer to the User manual (in PDF format) for details on how to open/close the nanoSIM card and microSD card tray.

- To maintain waterproof/dustproof performance, replacement of parts is recommended every 2 years regardless of whether the handset appears normal or abnormal. Sharp replaces the parts as a chargeable service. Contact the number listed in "General Inquiries" on the warranty for information on replacing parts.

## Precautions

---

- When your hands are wet or water/foreign object is on the handset, do not open/close the nanoSIM card and microSD card tray.
- Close the nanoSIM card and microSD card tray properly. Even a fine obstacle (one hair, one grain of sand, tiny fiber, etc.) put between contact surfaces may allow liquids or dust to get inside.
- If the handset gets wet with water or other liquids with the nanoSIM card and microSD card tray opened, the liquid may get inside causing an electric shock or a malfunction. Stop using the handset, turn off the power and contact the number listed in "General Inquiries" on the warranty.
- The rubber gasket of the contact surface between the main body and the nanoSIM card and microSD card tray plays an important role in maintaining the waterproof/dustproof performance. Do not remove or scratch it. Also, prevent dust from adhering to it.  
If the rubber gasket is damaged or deformed, contact the number listed in "General Inquiries" on the warranty.
- Do not insert a pointed object through the nanoSIM card and microSD card tray gaps. It may cause damage to the rubber gasket and allow liquids or dust to get inside.
- Do not use the handset underwater (including key operations). May cause a malfunction.
- Do not directly apply water flow stronger than allowed (over 6 L/min). May cause malfunction though SH-M12 provides waterproof performance of IPX5.
- Do not let the handset get wet with liquids other than water at room temperature (between 5°C and 35°C) or do not soak the handset in the liquids. If you let the handset get wet with liquids other than water at room temperature or soak the handset in the liquids, stop using the handset and wash it with water at room temperature.
- Do not wash the handset in a washing machine etc.
- To prevent condensation, wait until the handset reaches room temperature before you bring it from a cold place to a warm place.
- Never soak the handset in hot spring water or water containing soap, detergent or bath powder.
- Do not soak the handset in hot water, use it in a sauna or apply hot air (from a hair dryer, etc.) to it.
- Do not soak the handset in seawater.
- Do not put the handset directly on sand/dirt.

- If foreign object such as salt water, seawater, drink, seasoning, food, dirt or soil adheres to the handset, rinse it off immediately. If it becomes dry and hard, it is difficult to remove it and may cause damage or malfunction.
- Do not leave the handset wet. In cold places, water may freeze and cause malfunction.
- The handset does not float on water.
- Do not let the handset fall. It may become scratched and cause the waterproof/dustproof performance to degrade.
- Do not leave water on the mouthpiece/microphone, earpiece/speaker or earphone/microphone terminal. Such water may interfere with talking.
- Do not poke the mouthpiece/microphone, earpiece/speaker, USB Type-C connection jack, earphone/microphone terminal, etc. with a pointed object.
- Do not insert an earphone/microphone to the handset while the handset is wet. May cause a malfunction.
- The specified AC adapter is not waterproof/dustproof. Do not use them in rooms where water is regularly in use such as bathroom, shower room, kitchen or lavatory.



Soap/Detergent/  
Bath powder



Seawater



Swimming  
pool



Hot spring



Sand/Mud

- Sharp does not guarantee actual operations under all states. Malfunctions deemed to be caused by inappropriate operation by the customer are not covered by the warranty.

## Draining water when the handset gets wet

When the handset is wet, water may flow out after wiping it off. Drain the water by following the steps below.

- 1 Wipe off water on the handset surface with dry and clean cloth etc.**



- 2 Shake the handset approximately 20 times, securely holding it, until there is no more water splattering**



To drain water off the mouthpiece/microphone, shake the handset with the mouthpiece turned down.



To drain water off the earpiece/speaker, shake the handset with the earpiece/speaker turned down.

**3 Softly press the handset against dry and clean cloth etc. to wipe off water remaining in the grooves of the mouthpiece/microphone, earpiece/speaker, keys, USB Type-C connection jack, earphone/microphone terminal, etc.**

- Pat the opening with cloth etc. to remove water because there may be any water remaining in the grooves of each part.

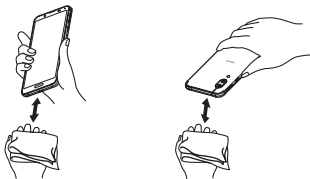

**4 Wipe off water oozing from the handset with dry and clean cloth etc. and dry naturally for approximately 3 hours**

- Water, if any, remaining in the main body may ooze after wiping off.
- Pat the opening with cloth etc. again to remove water because you may not be able to hear sounds well if drainage is insufficient.

## Charging

**The specified AC adapter is not waterproof/dustproof. Check the followings before and after charging.**

- Make sure that there is no water or foreign object on the handset. If foreign object adheres to the handset, immediately rinse it off. Also, if the handset is wet or after the handset is wet, adequately drain it and wipe off water with dry and clean cloth etc. then dry naturally before charging.

## Warning

**Never try to connect the USB Type-C plug when the handset is wet or foreign object adheres to the handset.**

- The handset provides waterproof/dustproof performance, however, inserting the USB Type-C plug while the equipment is wet or dirty may cause a short circuit when you charge the battery and lead to abnormal overheating, a malfunction, a fire or burns due to the water, foreign object, etc. adhering to the handset or USB Type-C plug.
- Do not touch an AC adapter with your hands wet. May cause electric shock.
- Do not use the AC adapter in a place subject to water. Do not use it in rooms where water is regularly in use such as bathroom, shower room, kitchen or lavatory. May cause fires or electric shock.

## Replacing the Internal Battery

The internal battery is not covered by warranty because it is a consumable product.

Although battery life will differ depending on usage conditions and operating environment, it will eventually deteriorate after repeated charging and use. Replace the battery with a new one if its life becomes extremely short even after fully charged or if it swells.

You cannot replace the internal battery by yourself. Contact the number listed in “General Inquiries” on the warranty and request replacement of the internal battery (a fee will be charged).

## Recycling

The lithium-ion battery used in this handset is a useful resource that can be recycled. Please recycle.

Contact the number listed in “General Inquiries” on the warranty for information on recycling.



**Li-ion00**

### ■ When disposing of this product

- Dispose of this product in accordance with the disposal regulations of your local government. As the regulations may differ depending on the local government, be sure to check the rules in your community.
- In order to protect your privacy, perform [Erase all data (factory reset)] beforehand to delete all data in the system memory.

## Regulatory Information

Hereby, SHARP CORPORATION declares that the radio equipment type SH-M12 is in compliance with Directive 2014/53/EU.

The full text of the EU declaration of conformity is available at the following internet address:

<https://jp.sharp/k-tai/>

Manufacturer's Address:

SHARP CORPORATION,

1 Takumi-cho, Sakai-ku, Sakai-shi, Osaka 590-8522, Japan

### CE/ FCC Notice

Before use, refer to the User manual (in PDF format) and read CE/FCC Notice and detailed operation manual to ensure proper operation.

Download URL: <http://k-tai.sharp.co.jp/support/other/shm12/manual/index.html>

### FCC ID Location

The device is electronically labeled and the FCC ID can be displayed via the System, the Advanced & the Authentication under the Settings menu.

## Copyrights and rights of portrait

---

- Data with third party copyrights such as text, images, music and software that is downloaded via Internet websites, acquired by TV, video, etc. or shot by the handset cannot be duplicated, altered or publicly transmitted without rightful party's consent. Only duplicating, quoting, etc. for personal use are permitted under the Copyright Act.

Even if for personal use, filming and recording may be prohibited for stage performances, shows, exhibitions, etc. Also, shooting another's image or posting another's image on Internet websites without his/her consent may constitute a violation of one's right to his/her image.

## Registered trademarks and trademarks

---

- QR code is a registered trademark of Denso Wave Inc.
- microSD Logo, microSDHC Logo and microSDXC Logo are trademarks of SD-3C, LLC.



- USB Type-C™ is a trademark of USB Implementers Forum.
-  is a registered trademark of FeliCa Networks, Inc.
- FeliCa is a contactless IC card technology developed by Sony Corporation. FeliCa is a registered trademark of Sony Corporation.
- "Osai-fu-Keitai" is a registered trademark of NTT DOCOMO, INC.
- Bluetooth is a registered trademark of Bluetooth SIG, Inc.
- Wi-Fi® is a registered trademark of Wi-Fi Alliance®.
- Google, Google Play and Gmail are trademarks of Google LLC.
- "AQUOS", "emopa", "AQUOS" logo, and "AQUOS sense3" logo are trademarks or registered trademarks of Sharp Corporation.
- All other company names and product names are trademarks or registered trademarks of the respective companies.



## Others

---

- Under the MPEG-4 Visual Patent Portfolio License, customers have licensed permission for the following use of this product to engage in non-profit personal use. Other uses are not permitted.
  - Encoding MPEG-4 standard video (henceforth referred to as MPEG-4 video).
  - Decoding an MPEG-4 video that a customer not engaged in personal commercial activities has encoded.
  - Decoding an MPEG-4 video obtained from a licensed provider.For details on other intended uses, contact MPEG LA, LLC.
- This product is licensed under the AVC patent portfolio license for the personal and noncommercial use of a consumer to (i) encode video in compliance with the AVC standard (henceforth referred to as AVC video) and/or (ii) decode AVC video that was encoded by a consumer engaged in a personal and noncommercial activity and/or was obtained from a video provider licensed to provide AVC video. No license is granted or shall be implied for any other use. Additional information may be obtained from MPEG LA, L.L.C.  
Refer to <https://www.mpegla.com>.

## Open source software

---

- This product includes software based on GNU General Public License (GPL), GNU Lesser General Public License (LGPL) and other licenses.  
For details on the licenses of related software, select home screen ► [] ► [System] ► [About phone] ► [Legal information] ► [Third-party licenses].
- Source codes of software based on GPL, LGPL and Mozilla Public License (MPL) can be referred to on the following website for free. For details, refer to the following website.  
<http://k-tai.sharp.co.jp/support/developers/oss/>



危険です、  
歩きスマホ。



キケン!  
水ぬれ充電



あぶない!  
電池への衝撃



Li-ion00



Manufacturer:  
Sharp Corporation

R220SHM12F/PLENCDKJA